

# \*TB 9-6625-2170-35

SUPERSEDED COPY DATED 15 OCTOBER 1990

## DEPARTMENT OF THE ARMY TECHNICAL BULLETIN

# CALIBRATION PROCEDURE FOR DISTORTION ANALYZER, TS-4084/G

Headquarters, Department of the Army, Washington, DC

15 December 2000

*Approved for public release; distribution is unlimited*

### REPORTING OF ERRORS AND RECOMMENDING IMPROVEMENTS

You can help improve this publication. If you find any mistakes or if you know of a way to improve the procedure, please let us know. Mail your letter or DA Form 2028 to: Commander, U. S. Army Aviation and Missile Command, ATTN: AMSAM-MMC-LS-LP, Redstone Arsenal, AL 35898-5230. A reply will be furnished to you. You may also send in your comments electronically to our e-mail address: [ls-lp@redstone.army.mil](mailto:ls-lp@redstone.army.mil) or by FAX (256) 842-6546/DSN 788-6546.

		<b>Paragraph</b>	<b>Page</b>
SECTION	I.	IDENTIFICATION AND DESCRIPTION	
		Test instrument identification .....	1 2
		Forms, records, and reports .....	2 2
		Calibration description.....	3 2
	II.	EQUIPMENT REQUIREMENTS	
		Equipment required.....	4 3
		Accessories required.....	5 3
	III.	CALIBRATION PROCESS	
		Preliminary instructions.....	6 3
		Equipment setup .....	7 4
		Common mode rejection .....	8 4
		Level volts.....	9 5
		DBm and dB ratio .....	10 8
		Level bandwidth and filters .....	11 10
		Residual noise.....	12 11
		Distortion measurement accuracy .....	13 11
		Residual THD + N.....	14 13
		Power supply .....	15 14
		Final procedure .....	16 14

**SECTION I  
IDENTIFICATION AND DESCRIPTION**

**1. Test Instrument Identification.** This bulletin provides instructions for the calibration of Distortion Analyzer, TS-4084/G. The TM 11-6625-3152-14 was used as the prime data source in compiling these instructions. The equipment being calibrated will be referred to as the TI (test instrument) throughout this bulletin.

**a. Model Variations.** None.

**b. Time and Technique.** The time required for this calibration is approximately 2 hours, using the dc and low frequency technique.

**2. Forms, Records, and Reports**

**a.** Forms, records, and reports required for calibration personnel at all levels are prescribed by TB 750-25.

**b.** Adjustments to be reported are designated (R) at the end of the sentence in which they appear. When adjustments are in tables, the (R) follows the designated adjustment. Report only those adjustments made and designated with (R).

**3. Calibration Description.** TI parameters and performance specifications which pertain to this calibration are listed in table 1.

Table 1. Calibration Description

Test instrument parameters	Performance specifications
Common mode rejection	≥50 dB at 50 to 60 Hz
Volts (dB)	Range: 200 μV to 200 V Accuracy: ±2% +1 count (±0.3 dB) 20 Hz to 20 kHz ±4% +2 counts (±0.5 dB) 10 to 20 Hz and 20 to 100 kHz
Level bandwidth	At least 300 kHz at 3 dB down (no filters selected)
Filters	Range: -3 dB at 400 Hz high pass (at least 40 dB rejection at 60 Hz) -3 dB at 80 kHz low pass -3 dB at 30 kHz low pass Accuracy: ±5% A weighting: 100 Hz- 19.1 ±1 dB 1 kHz 0 ±1 dB 10 kHz -3.5 ±3 dB
Residual noise	Accuracy: ≤3 μV with 80 kHz and 400 Hz filters Accuracy: ≤1.5 μV with A weighting filter
Distortion measurement	Fundamental frequency: 20 Hz to 20 kHz Accuracy: ±0.1% Fundamental frequency: 10 to 20 Hz, 20 to 100 kHz Accuracy: ±0.2%
Residual THD + N	Range: 20 Hz to 20 kHz with 80 kHz filter Distortion: ≤0.005% (-86 dB) Range: 10 to 20 Hz and 20 to 100 kHz Distortion: ≤0.015% (-76.5 dB)

**SECTION II  
EQUIPMENT REQUIREMENTS**

**4. Equipment Required.** Table 2 identifies the specific equipment to be used in this calibration procedure. This equipment is issued with Secondary Transfer Calibration Standards Set AN/GSM-286. Alternate items may be used by the calibrating activity. The items selected must be verified to perform satisfactorily prior to use and must bear evidence of current calibration. The equipment must meet or exceed the minimum use specifications listed in table 2. The accuracies listed in table 2 provide a four-to-one ratio between the standard and TI.

**5. Accessories Required.** The accessories required for this calibration are common usage accessories issued as indicated in 4 above, and are not listed in this calibration procedure.

Table 2. Minimum Specifications of Equipment Required

Common name	Minimum use specifications	Manufacturer and model (part number)
AC DIVIDER	Range: 1000:1 Frequency: 10 Hz to 40 kHz	John Fluke, Model 7405A-4207 (7405A-4207)
CALIBRATOR	Range: 3 mV to 100 V Frequency: 10 Hz to >300 kHz Accuracy: ±0.5%	John Fluke, Model 5700A/CT (p/o MIS-35947)
MULTIMETER	Range: 4.98 to 5.51 V dc Accuracy: ±0.476%	John Fluke, Model 8840A/AF (AN/GSM-64D)
OSCILLATOR	Frequency: 10 Hz to 100 kHz Amplitude range: -10 to 0 dBm Distortion: <0.005%	Tektronix, Type SG-505 (MIS-30526/11)
OSCILLOSCOPE	Capabilities Vertical: 200 mV/div dc coupling Horizontal: 200 ms/div	Tektronix, Type 2465BOPT46 (2465BOPT46)
TRUE RMS VOLTMETER	Range: 1 mV to 1.58 V Accuracy: ±0.75%	John Fluke, Model 8922A/AA (8922A/AA)

**SECTION III  
CALIBRATION PROCESS**

**6. Preliminary Instructions**

**a.** The instructions outlined in paragraphs 6 and 7 are preparatory to the calibration process. Personnel should become familiar with the entire bulletin before beginning the calibration.

**b.** Items of equipment used in this procedure are referenced within the text by common name as listed in table 2.

**c.** Unless otherwise specified, verify the result of each test and, whenever the test requirement is not met, take corrective action before continuing with the calibration. Adjustments required to calibrate the TI are included in this procedure. Additional maintenance information is contained in TM 11-6625-3152-14 for this TI.

## **TB 9-6625-2170-35**

**d.** When indications specified in paragraphs **8** through **14** are not within tolerance, perform the power supply check prior to making adjustments. After adjustments are made, repeat paragraphs **8** through **14**. Do not perform power supply check if all other parameters are within tolerance.

**e.** Unless otherwise specified, all control and control settings refer to the TI.

### **7. Equipment Setup**

#### **WARNING**

HIGH VOLTAGE is used or exposed during the performance of this calibration. DEATH ON CONTACT may result if personnel fail to observe safety precautions. REDUCE OUTPUT(S) to minimum after each step within the performance check where applicable.

**a.** Remove protective cover from TI only as necessary to make adjustments or gain access to test points. Replace cover upon completion of test.

**b.** Press and release TI **REAR INTFC/INPUT** pushbutton to **INPUT**.

**c.** Connect TI to a 115 V ac source.

**d.** Set **POWER** switch to **ON** and allow at least 30 minutes for warmup.

### **8. Common Mode Rejection**

#### **a. Performance Check**

(1) Connect calibrator **OUTPUT HI** and **LO** to TI **INPUT +** and ground terminal.

(2) Connect TI **INPUT -** to +.

(3) Connect TI **FUNCTION OUTPUT** to true rms voltmeter **INPUT**.

(4) Position controls as listed in (a) through (e) below:

(a) **INPUT RANGE** switch to **200  $\mu$ V**.

(b) **FUNCTION VOLTS** pushbutton pressed.

(c) **FUNCTION LEVEL** pushbutton pressed.

(d) **RESPONSE RMS/AVG** pushbutton pressed to **RMS**.

(e) All **FILTERS** pushbuttons released.

(5) Set calibrator for a 50 mV, 50 Hz output. True rms voltmeter indication will be  $\leq$  1.58 V.

(6) Set calibrator frequency to 60 Hz. True rms voltmeter indication will be  $\leq$  1.58 V.

(7) Repeat technique of (4)(a), (5), and (6) above using settings listed in table 3. True rms voltmeter will indicate within limits specified.

Table 3. Common Model Rejection

Test instrument <b>INPUT RANGE</b> switch settings	Calibrator output settings (50 and 60 Hz)	True rms voltmeter indications (mV)
2 mV	50 mV	≤158.0
20 mV	50 mV	≤15.8
200 mV	0.1 V	≤3.2
600 mV	0.3 V	≤1.0
2 V	1 V	≤3.2
6 V	3 V	≤1.0
20 V	10 V	≤3.2
60 V	30 V	≤1.0
200 V	100 V	≤3.2

**b. Adjustments.** No adjustments can be made.

**9. Level Volts**

**a. Performance Check**

- (1) Connect ac divider **INPUT HI** and **LO** to calibrator **OUTPUT HI** and **LO**.
- (2) Connect ac divider **OUTPUT** to TI **INPUT +** and **-**.
- (3) Position controls as listed in (a) through (e) below:
  - (a) **INPUT RANGE** switch to **200 μV**.
  - (b) **FUNCTION VOLTS** pushbutton pressed.
  - (c) **FUNCTION LEVEL** pushbutton pressed.
  - (d) **RESPONSE RMS/AVG** pushbutton pressed to **RMS**.
  - (e) All **FILTERS** pushbuttons released.
- (4) Set calibrator for a 100 mV, 50 Hz output. If TI does not indicate between 97.9 and 102.1 μV, perform **b** below.
- (5) Repeat technique of (3)(a) and (4) above using settings listed in table 4. If TI does not indicate within limits specified, perform **b** below.

Table 4. Level Volts

Test instrument <b>INPUT RANGE</b> switch settings	Calibrator		Test instrument indications	
	Amplitude settings	Frequency settings	Min	Max
200 μV	100 mV	10 kHz	97.9 μV	102.1 μV
200 μV	100 mV	40 kHz	95.8 μV	104.2 μV
2 mV	1.8 V	10 Hz	1.726 mV	1.874 mV
		10 kHz	1.763 mV	1.837 mV
20 mV <sup>1</sup>	18 mV	10 Hz	17.26 mV	18.74 mV
		10 kHz	17.63 mV	18.37 mV
		100 kHz	17.26 mV	18.74 mV

<sup>1</sup>Remove ac divider from equipment setup for this and remaining checks.

Table 4. Level Volts - Continued

Test instrument <b>INPUT RANGE</b> switch settings	Calibrator		Test instrument indications	
	Amplitude settings	Frequency settings	Min	Max
200 mV	180 mV	100 kHz	172.6 mV	187.4 mV
		10 kHz	176.3 mV	183.7 mV
		10 Hz	172.6 mV	187.4 mV
600 mV	500 mV	10 Hz	478 mV	522 mV
		10 kHz	489 mV	511 mV
		100 kHz	478 mV	522 mV
2 V	1.8 V	100 kHz	1.726 V	1.874 V
		10 kHz	1.763 V	1.837 V
		10 Hz	1.726 V	1.874 V
6 V	5 V	10 Hz	4.78 V	5.22 V
		10 kHz	4.89 V	5.11 V
		100 kHz	4.78 V	5.22 V
20 V	18 V	100 kHz	17.26 V	18.74 V
		10 kHz	17.63 V	18.37 V
		10 Hz	17.26 V	18.74 V
60 V	50 V	10 Hz	47.8 V	52.2 V
		10 kHz	48.9 V	51.1 V
		100 kHz	47.8 V	52.2 V
200 V	100 V	100 kHz	95.8 V	104.2 V
		10 kHz	97.9 V	102.1 V
		10 kHz	95.8 V	104.2 V

**b. Adjustments**

- (1) Disconnect equipment from TI **INPUT**.
- (2) Position controls as listed in (a) through (d) below:
  - (a) **INPUT RANGE** switch to **2V**.
  - (b) **FUNCTION THD + N** pushbutton pressed.
  - (c) **FILTERS 80 kHz LO PASS** pushbutton pressed.
  - (d) Distortion range **0.2%** pushbutton pressed.
- (3) Short TI **INPUT** - and +.
- (4) Connect oscilloscope **CH1** to TI **FUNCTION OUTPUT**.
- (5) Position oscilloscope controls for 200 mV/div, dc coupled and 200 ms/div sweep.
- (6) Press distortion range **2%** and **0.2%** pushbuttons in turn and note oscilloscope display jump amplitude. If jump amplitude is 100 mV or greater, adjust R1050 (fig. 1) for minimum jump amplitude, less than 100 mV, when switching between 2% and 0.2% (R).

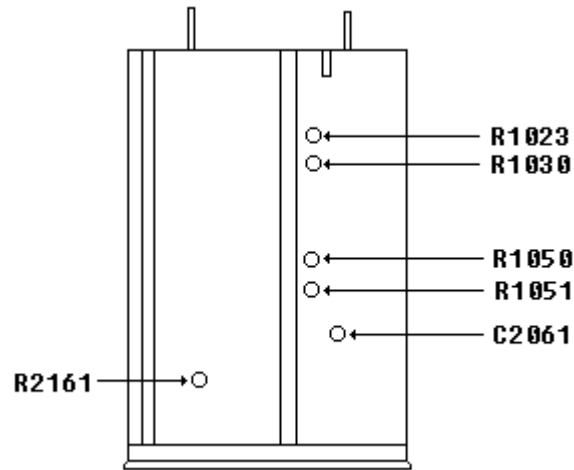

Figure 1. Test instrument - top view.

- (7) Disconnect short and oscilloscope from TI.
- (8) Connect calibrator **OUTPUT HI** and **LO** to TI **INPUT +** and **-**.
- (9) Position controls as listed in (a) through (d) below:
  - (a) **FILTERS 80 kHz LO PASS** pushbutton released.
  - (b) **FUNCTION LEVEL** pushbutton pressed.
  - (c) **FUNCTION VOLTS** pushbutton pressed.
  - (d) **RESPONSE RMS/AVG** pushbutton pressed to **RMS**.
- (10) Set calibrator for a 15 mV, 1 kHz output.
- (11) Adjust RMS 0 (fig. 2) until TI indicates 0.015 V (R).

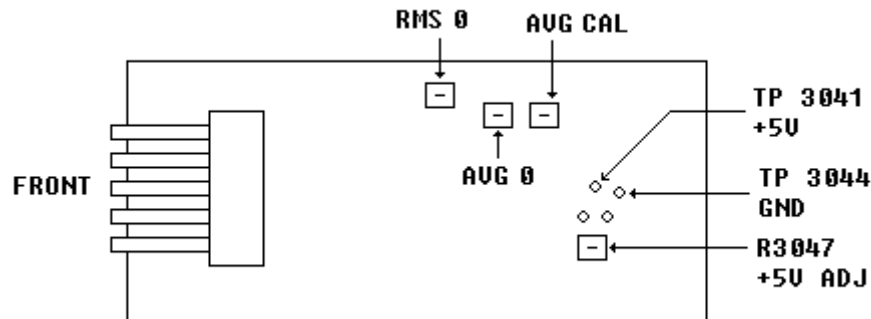

Figure 2. Test instrument - right view.

- (12) Press **FUNCTION dBm 600Ω** pushbutton and record TI indication.
- (13) Release **RESPONSE RMS/AVG** pushbutton to **AVG** and adjust AVG 0 (fig. 2) until TI indicates same value recorded in (12) above (R).

## TB 9-6625-2170-35

- (14) Press **FUNCTION VOLTS** pushbutton.
- (15) Press **RESPONSE RMS/AVG** pushbutton to **RMS**.
- (16) Set calibrator for a 1.5 V, 1 kHz output.
- (17) Adjust RMS CAL (fig. 3) until TI indicates 1.500 V  $\pm$ 0.001 V (R).

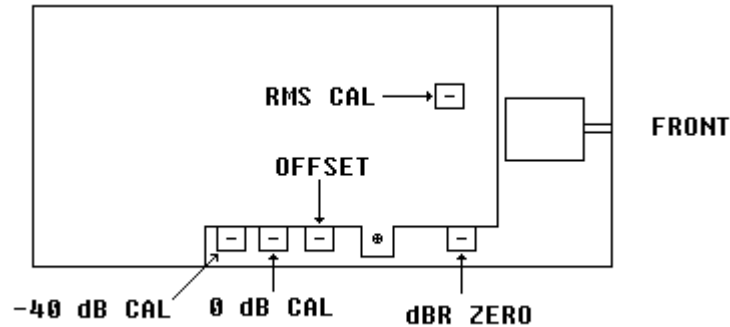

Figure 3. Test instrument - left view.

- (18) Release **RESPONSE RMS/AVG** pushbutton to **AVG**.
- (19) Adjust AVG CAL (fig. 2) until TI indicates 1.500 V  $\pm$ 0.001 V (R).
- (20) Press **RESPONSE RMS/AVG** pushbutton to **RMS**.
- (21) Set calibrator for a 1 V, 60 kHz output.
- (22) Record TI indication.
- (23) Set **INPUT RANGE** switch to **20 V**.
- (24) Set calibrator amplitude to 10.00 V.
- (25) Adjust C2061 (fig. 1) for a TI indication 10 times greater than that recorded in (22) above (R).

## 10. dBm and dB Ratio

### a. Performance Check

- (1) Connect calibrator **OUTPUT HI** and **LO** to TI **INPUT +** and **-**.
- (2) Position controls as listed in (a) through (d) below:
  - (a) **INPUT RANGE** switch to **AUTO RANGE**.
  - (b) **FUNCTION dBm 600 $\Omega$**  pushbutton pressed.
  - (c) **FUNCTION LEVEL** pushbutton pressed.
  - (d) All **FILTERS** pushbuttons released.
- (3) Set calibrator for a 774.6 mV, 1 kHz output. If TI does not indicate between -00.3 and +00.3 dBm, perform **b(1)** through (11) below.



(4) Repeat technique of (3) above using settings listed in table 5. If TI does not indicate within limits specified, perform **b(1)** through (11) below.

Table 5. dBm

Calibrator settings		Test instrument indications (dBm)	
Frequency (kHz)	Amplitude (mV)	Min	Max
1	244.95	-09.7	-10.3
1	77.46	-19.7	-20.3
1	24.495	-29.7	-30.3
1	7.746	-39.7	-40.3

(5) Set calibrator for a 774.6 mV, 1 kHz output.

(6) Press **FUNCTION dB RATIO** pushbutton and press and release **PUSH TO SET 0 dB REF** pushbutton. If TI does not indicate between -00.3 and +00.3 dB, perform **b(12)** through (15) below.

(7) Set calibrator frequency to 10 Hz. If TI does not indicate between -00.5 and +00.5 dB, perform **b(12)** through (15) below.

(8) Repeat technique of (7) above using settings listed in table 6. If TI does not indicate within limits specified, perform **b(12)** through (15) below.

Table 6. dB Ratio

Calibrator frequency settings	Test instrument indications (dB)	
	Min	Max
20 Hz	-00.3	+00.3
20 kHz	-00.3	+00.3
100 kHz	-00.5	+00.5

(9) Set calibrator for a 100 V, 1 kHz output.

(10) Press and release **PUSH TO SET 0 dB REF** pushbutton.

(11) Set calibrator amplitude to 1 mV. TI will indicate between -99.3 and -100.7 dB.

**b. Adjustments**

(1) Set **INPUT RANGE** switch to **2V**.

(2) Set calibrator for a 774.6 mV, 1 kHz output.

(3) Adjust 0 dB CAL (fig. 3) until TI indicates 00.0 dBm (R).

(4) Set calibrator amplitude to 77.46 mV.

(5) Adjust R2161 (fig. 1) until TI indicates -20.0 dBm (R).

(6) Set calibrator amplitude to 7.746 mV.

## **TB 9-6625-2170-35**

- (7) Adjust -40 dB CAL (fig. 3) until TI indicates -40.0 dBm (R).
- (8) Repeat (2) through (7) above for best in-tolerance condition.
- (9) Set **INPUT RANGE** switch to **20 mV**.
- (10) Set calibrator amplitude to 7.746 mV.
- (11) Adjust OFFSET (fig. 3) until TI indicates -40.0 dBm (R).
- (12) Set **INPUT RANGE** switch to **2 V**.
- (13) Set calibrator for a 774.6 mV, 1 kHz output.
- (14) Press **FUNCTION dB RATIO** and press and release **PUSH TO SET 0 dB REF** pushbutton.

### **NOTE**

Press and release **PUSH TO SET 0 dB REF** pushbutton after each increment adjustment of dBR ZERO.

- (15) Adjust dBR ZERO (fig. 3) in increments until TI displays 0.00 dB (R).

## **11. Level Bandwidth and Filters**

### **a. Performance Check**

- (1) Connect calibrator **OUTPUT HI** and **LO** to TI **INPUT +** and **-**.
- (2) Position controls as listed in (a) through (d) below:
  - (a) **INPUT RANGE** switch to **AUTO RANGE**.
  - (b) **FUNCTION dB RATIO** pushbutton pressed.
  - (c) **FUNCTION LEVEL** pushbutton pressed.
  - (d) All **FILTERS** pushbuttons released.
- (3) Set calibrator for a 1 V, 1 kHz output.
- (4) Press and release **FUNCTION PUSH TO SET 0 dB REF** pushbutton.
- (5) Increase calibrator frequency until TI indicates -3.0 dB. Calibrator frequency will be  $\geq 300$  kHz.
- (6) Press **FILTERS 400 Hz HI PASS** pushbutton.
- (7) Decrease calibrator frequency until TI indicates -3.0 dB. Calibrator frequency will be between 380 and 420 Hz.
- (8) Set calibrator frequency to 60 Hz. TI indication will be  $\leq -40$  dB.
- (9) Release **FILTERS 400 Hz HI PASS** pushbutton and press **FILTERS 80 kHz LO PASS** pushbutton.
- (10) Increase calibrator frequency until TI indicates -3.0 dB. Calibrator frequency will be between 76 and 84 kHz.
- (11) Release **FILTERS 80 kHz LO PASS** pushbutton and press **FILTERS 30 kHz LO PASS** pushbutton.

(12) Decrease calibrator frequency until TI indicates -3.0 dB. Calibrator frequency will be between 28.5 and 31.5 kHz.

(13) Release **FILTERS 30 kHz LO PASS** pushbutton and press **FILTERS A WTG** pushbutton.

(14) Set calibrator frequency to 100 Hz. TI will indicate between -18.1 and -20.1 dB.

(15) Set calibrator frequency to 1 kHz. TI will indicate between -1 and +1 dB.

(16) Set calibrator frequency to 10 kHz. TI will indicate between -6.5 and -0.5 dB.

**b. Adjustments.** No adjustments can be made.

## 12. Residual Noise

### a. Performance Check

(1) Position controls as listed in (a) through (g) below:

- (a) **INPUT RANGE** switch to **AUTO RANGE**.
- (b) **FUNCTION VOLTS** pushbutton pressed.
- (c) **FUNCTION LEVEL** pushbutton pressed.
- (d) **RESPONSE RMS/AVG** pushbutton pressed to **RMS**.
- (e) **FILTERS 400 Hz HI PASS** pushbutton pressed.
- (f) **FILTERS 80 kHz LO PASS** pushbutton pressed.
- (g) **FILTERS 30 kHz LO PASS** and **A WTG** pushbuttons released.

(2) Short TI **INPUT** + and - using a good quality short. TI indication will be  $\leq 3.0 \mu\text{V}$ .

(3) Release **FILTERS 400 Hz HI PASS** and **80 kHz LO PASS** pushbuttons and press **FILTERS A WTG** pushbutton. TI indication will be  $\leq 1.5 \mu\text{V}$ .

**b. Adjustments.** No adjustments can be made.

## 13. Distortion Measurement Accuracy

### a. Performance Check

(1) Connect equipment as shown in figure 4.

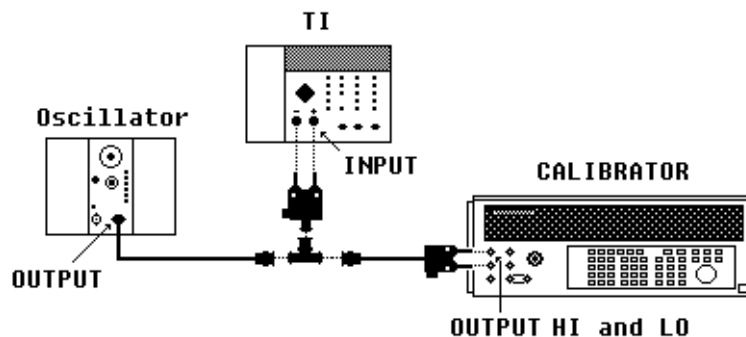

Figure 4. Distortion - equipment setup.

**TB 9-6625-2170-35**

- (2) Position controls as listed in (a) through (e) below:
  - (a) **INPUT RANGE** switch to **AUTO RANGE**.
  - (b) **FUNCTION VOLTS** pushbutton pressed.
  - (c) **FUNCTION LEVEL** pushbutton pressed.
  - (d) **RESPONSE RMS/AVG** pushbutton pressed to **RMS**.
  - (e) All **FILTERS** pushbuttons released.
- (3) Press and release oscillator **OUTPUT ON/OFF** pushbutton to **OFF**.
- (4) Set calibrator for a 3 mV, 7 kHz output. Adjust calibrator amplitude for a 3.00 mV TI indication.
- (5) Position oscillator **FREQUENCY Hz** controls for 400 Hz. Press oscillator **OUTPUT ON/OFF** pushbutton to **ON** and position **OUTPUT LEVEL(dBm)** controls for a 300 mV TI indication.
- (6) Press **FUNCTION THD + N** pushbutton. If TI does not indicate between 0.9 and 1.1 percent, perform **b** below.
- (7) Press **FUNCTION LEVEL** pushbutton.
- (8) Repeat technique of (3) through (7) above using frequencies listed in table 7. TI will indicate within limits specified.

Table 7. Distortion Accuracy

Calibrator frequency settings	Oscillator <b>FREQUENCY Hz</b> settings	Test instrument indications (%)	
		Min	Max
40 Hz 60 Hz 80 Hz 1 kHz	20 Hz	0.9	1.1
2 kHz 3 kHz 4 kHz 10 kHz	1 kHz	0.9	1.1
40 kHz 60 kHz 80 kHz 100 kHz	20 kHz	0.9	1.1
100 Hz	10 Hz	0.8	1.2
200 kHz 300 kHz	100 kHz	0.8	1.2

**b. Adjustments.** Adjust R1051 (fig. 1) until TI indicates 1.00% (R).

**14. Residual THD + N**

**a. Performance Check**

- (1) Connect oscillator output to TI **INPUT +** and **-**.
- (2) Connect TI **INPUT -** to ground terminal.
- (3) Position controls as listed in (a) through (c) below:
  - (a) **INPUT RANGE** switch to **AUTO RANGE**.
  - (b) Distortion range **AUTO RANGE** pushbutton pressed.
  - (c) All **FILTERS** pushbuttons released.
- (4) Position oscillator controls as listed in (a) through (d) below:
  - (a) **FREQUENCY Hz** for 100 kHz.
  - (b) **OUTPUT LEVEL (dBm)** for 0 dBm.
  - (c) **GNDED/FLTG** pushbutton released to **FLTG**.
  - (d) **OUTPUT ON/OFF** pushbuttons pressed to **ON**.
- (5) Press TI **FUNCTION THD + N** pushbutton. If TI indication is not  $\leq 0.015\%$ , perform **b** below.
- (6) Repeat technique of (4)(a) above using settings listed in table 8. If TI does not indicate within limits specified, perform **b** below.

Table 8. Residual THD + N

Oscillator <b>FREQUENCY Hz</b> settings	Test instrument indications
50 kHz	$\leq 0.015\%$
20 Hz <sup>1</sup>	$\leq 0.005\%$
1 kHz	$\leq 0.005\%$
20 kHz	$\leq 0.005\%$

<sup>1</sup>Press **FILTERS 80 kHz LO PASS** pushbutton.

**b. Adjustments**

- (2) Position controls as listed in (a) through (d) below:
  - (a) **INPUT RANGE** switch to **2 V**.
  - (b) Distortion range **0.2%** pushbutton pressed.
  - (c) **FILTERS 80 kHz LO PASS** pushbutton pressed.
  - (d) All remaining **FILTERS** pushbuttons released.

## **TB 9-6625-2170-35**

(3) Position oscillator **FREQUENCY Hz** controls for 400 Hz and **OUTPUT LEVEL(dBm)** controls for 0 dBm.

(4) Adjust R1030 (fig. 1) for minimum TI indication (R).

(5) Adjust R1023 (fig. 1) for minimum TI indication (R).

(6) Repeat (4) and (5) above, as necessary, due to interaction.

(7) Position oscillator **FREQUENCY Hz** controls for 800 Hz.

(8) Adjust R5025 (accessible through hole in bottom cover) for minimum TI indication (R). If R5025 has no effect, adjust to center position.

### **15. Power Supply**

#### **NOTE**

Do not perform power supply check if all other parameters are within tolerance.

#### **a. Performance Check.**

(1) Connect multimeter **INPUT HI** to TP 3041 +5V and **LO** to TP 3044 GND (fig. 2).

(2) If multimeter does not indicate between 4.98 and 5.51 V dc; adjust R3047 +5 V ADJ (fig. 2) until multimeter indicates  $5.25 \pm 0.1$  V dc (R).

### **16. Final Procedure**

**a.** Deenergize and disconnect all equipment.

**b.** Annotate and affix DA label/form in accordance with TB 750-25.

**TB 9-6625-2170-35**

**By Order of the Secretary of the Army:**

**Official:**

ERIC K. SHINSEKI  
*General, United States Army*  
*Chief of Staff*

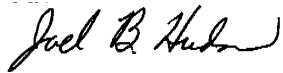

JOEL B. HUDSON  
*Administrative Assistant to the*  
*Secretary of the Army*  
0027704

**DISTRIBUTION:**

To be distributed in accordance with IDN 342259, requirements for calibration procedure TB 9-6625-2170-35.

**PIN: 063166-000**